

# **SCHRADER PACIFIC** Advanced Valves

**VALVES AERONAUTIQUES ET PRODUITS HAUTE PRESSION**

**AERONAUTIC VALVES AND HIGH PRESSURE PRODUCTS**



**Wheels, brakes**



**Hydraulic fluids**



**High pressure**



**Aerospace**

Reliable. Innovative.

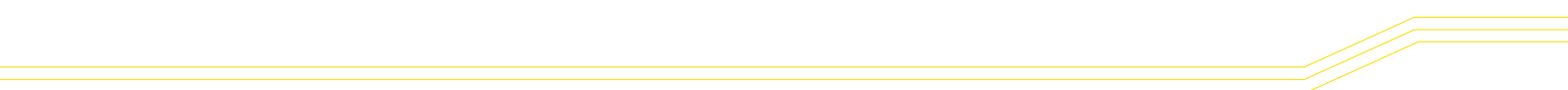

# **VALVES AERONAUTIQUES ET PRODUITS HAUTE PRESSION**

## ***AERONAUTIC VALVES AND HIGH PRESSURE PRODUCTS***

Les valves aéronautiques sont utilisées dans 2 domaines principaux :

- les roues avion
- les circuits hydrauliques haute pression (train d'atterrissage, circuit de frein)

*Aeronautic valves are mainly used in 2 fields:*

- *aircraft tyres*
- *high pressure hydraulic systems (shock absorbers, braking circuits)*

Toutes les valves destinées aux applications aéronautiques sont conçues et fabriquées afin de répondre parfaitement aux normes aéronautiques ainsi qu'aux exigences sévères des clients.

*All our valves for aeronautic applications are designed and manufactured in order to comply with aeronautic standards and meet customers requirements.*

Les valves et produits haute pression sont conçus et réalisés pour répondre à des environnements exigeants en température et/ou pression.

*Valves and high pressure products are both designed and produced to meet environment requirements in temperature and/or pressure.*

Tous les produits aéronautiques et haute pression font l'objet d'une fabrication particulièrement soignée et des contrôles extrêmement rigoureux permettent d'assurer le meilleur niveau de qualité.

*All our aeronautic and high pressure products are manufactured with the greatest attention and rigorous controls to guarantee the best quality level.*

**Matière : Acier inox**

***Material: Stainless steel***

# VALVES ROUE AVION AIRCRAFT TYRE VALVES

**Débit standard**  
*Standard flow*



	34919-03	42275-03	41828-03	41033-03C	42636-03
<b>A</b>	65	65	39.7	33.6	50.8
<b>B</b>	9.5	9.5	9.5	11.15	11.15
<b>C</b>	Ø 12.7x1.27 UNJF-3A 12-20" UNJF-3A	Ø 12.7x1.27 UNJF-3A 12-20" UNJF-3A	Ø 12.7x1.27 UNJF-3A 12-20" UNJF-3A	Ø 7.937x1.058 UNJF-3A 5/16-24" UNJF-3A	Ø 7.937x1.058 UNJF-3A 5/16-24" UNJF-3A
<b>Mécanisme Core</b>	29112-06	29112-06	29112-06	32287-00	32287-00
<b>Bouchon Cap</b>	28718-57 jaune/yellow	28718-57 jaune/yellow	28718-57 jaune/yellow	28718-57 jaune/yellow	28718-57 jaune/yellow
<b>Norme Standard</b>	TR 761-03	TR 761-03L	TR 756-03L	TR 752-03 (MS27436-C1)	TR 753-03 (MS27436-C2)
<b>Trous de fil-frein Lockwire holes</b>	Non / No	Oui / Yes	Oui / Yes	Non / No	Non / No

Echelle 1 / scale 1

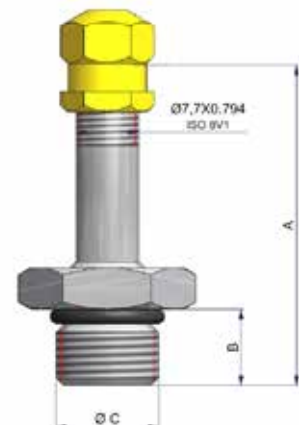

# VALVES ROUE AVION

## AIRCRAFT TYRE VALVES

### Gros débit

#### High flow



	37569-03	42096-03
<b>A</b>	35.5	35.5
<b>B</b>	9.5	9.5
<b>C</b>	Ø 12.7x1.27 UNJF-3A1 2-20" UNJF-3A	Ø 12.7x1.27 UNJF-3A1 2-20" UNJF-3A
<b>Mécanisme</b> <i>Core</i>	32283-00	32283-00
<b>Bouchon</b> <i>Cap</i>	29602-01	29602-01
<b>Norme</b> <i>Standard</i>	TRJ 780-03	TRJ 780-03L
<b>Trous de fil-frein</b> <i>Lockwire holes</i>	Non / No	Oui / Yes

Echelle 1 / scale 1

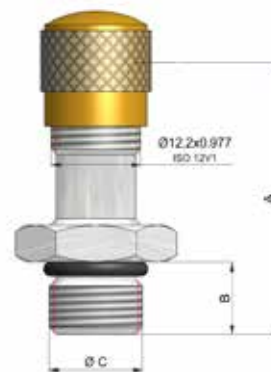

# VALVES HAUTE PRESSION HIGH PRESSURE VALVES



	Type 1				Type 2		
	41645-67	43282-00A	41690-67	43315-00A	42301-00	34926-52	34927-52
<b>Pression d'utilisation</b> <i>Working pressure</i>	0-345 bar	0-345 bar	0-345 bar	0-345 bar	0-250 bar	0-250 bar	0-250 bar
<b>A</b>	39.7	39.7	39.7	39.7	40.5	40.5	40.5
<b>B</b>	26	26	26	26	29.3	29.3	29.3
<b>C</b>	9.1	9.1	9.1	9.1	7.2	7.2	7.2
<b>D</b>	1.8 max	1.8 max	1.8 max	1.8 max	0.6	0.6	0.6
<b>Mécanisme</b> <i>Core</i>	---	---	---	---	29112-06	29112-06	---
<b>Bouchon</b> <i>Cap</i>	32069-01 nickelé <i>nickel plated</i>	32069-01 nickelé <i>nickel plated</i>	28718-57 jaune <i>yellow</i>	28718-57 jaune <i>yellow</i>	28718-57 jaune <i>yellow</i>	28718-54 bleu <i>blue</i>	28718-54 bleu <i>blue</i>
<b>Joint</b> <i>O-Ring</i>	EPDM	EPDM	NBR	EPDM	NBR	NBR	NBR
<b>Norme</b> <i>Standard</i>	---	---	MS28889-2	M6164-5	AN-6287	AN-6287	AN-6287
<b>Commentaire</b> <i>Comment</i>	Compatible avec liquide hydraulique Skydrol 500A <i>Compatible with Skydrol 500A hydraulic fluid</i>	Compatible avec liquide hydraulique NSA 307110 <i>Compatible with NSA 307110 hydraulic fluid</i>	Compatible avec <i>Compatible with</i> MIL-PRF-5606 MIL-PRF-83282 AIR 3515/B AIR 3520/B				

Echelle 1 / scale 1

EPDM = Ethylène-propylène-diène monomère  
*Ethylene-propylene-diene monomer*

NBR = Nitrile-butadiène  
*Nitrile-butadiene*

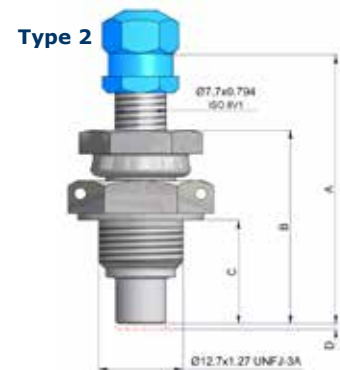
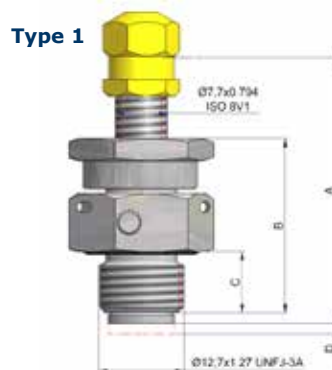

# VALVES HAUTE PRESSION

## HIGH PRESSURE VALVES



	41531-00	42582-00
<b>Pression d'utilisation</b> <i>Working pressure</i>	0-140 bar	0-200 bar
<b>A</b>	40.1	28
<b>B</b>	17.5	13.2
<b>Mécanisme</b> <i>Core</i>	29112-06	41071-06
<b>Bouchon</b> <i>Cap</i>	28718-57 jaune <i>yellow</i>	28718-57 jaune <i>yellow</i>
<b>Norme</b> <i>Standard</i>	AN-812-1	---
<b>Trous de fil-frein</b> <i>Lockwire holes</i>	Oui / Yes	Non / No

Echelle 1 / scale 1

Note : valves livrées sans joint torique  
*Note: valves delivered without O-ring*

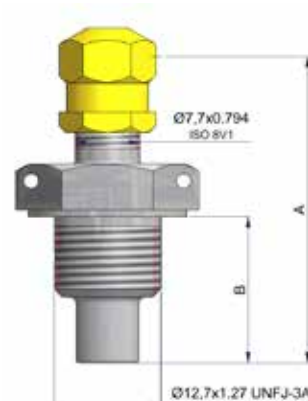

# RACCORDS DE GONFLAGE HP HIGH PRESURE INFLATING CONNECTORS



	32268-67	32289-67	32302-67	32284-67	32163-67	32423-67A
	5784	6116	5007	556	2755	2755L
<b>Filetage Thread</b>	7.7 x 0.794	7.7 x 0.794	7.7 x 0.794	7.7 x 0.794	7.7 x 0.794	12.7 x 0.977
<b>Dimension arrivée d'air Air line connection</b>	Filetage 7/16"-20 pour tube 1/4" Flare 7/16"-20 thread for 1/4" Flare tube fitting (MS 33656E4)	1/8" NPT Femelle 1/8" NPT Female	Filetage 7/16"-20 pour tube 1/4" Flare 7/16"-20 thread for 1/4" Flare tube fitting (MS 33656E4)	1/8" NPT Mâle 1/8" NPT Mal	Filetage 3/8"-24 pour tube 3/16" Flare 3/8"-24 thread for 3/16" Flare tube fitting (MS 33656E3)	Filetage 3/8"-24 pour tube 3/16" Flare 3/8"-24 thread for 3/16" Flare tube fitting (MS 33656E3)
<b>Pression maximum (psi) Maximum pressure (psi)</b>	5 000	3 000	15 000	3 000	3 000	3 000
<b>Remarques Remarks</b>	Joint fibre Hard fiber sealing washer	Joint fibre Hard fiber sealing washer	Joint cuivre Copper sealing washer	Avec dépresseur et joint cuivre With core depressor pin and copper sealing washer	Avec dépresseur et joint cuivre With core depressor pin and copper sealing washer	Avec dépresseur et joint cuivre With core depressor pin and copper sealing washer

Echelle 1 / scale 1



Schrader s.a.s. - B.P. 29  
48, rue de Salins - 25301 Pontarlier cedex - France  
Tél. : +33 (0) 381 38 56 56  
E-mail : [oe.info@schrader-pacific.fr](mailto:oe.info@schrader-pacific.fr)



[www.schrader-pacific.fr](http://www.schrader-pacific.fr)  
[www.aircraft-valves.com](http://www.aircraft-valves.com)